

HOMESTORY

WOHNEN, WIE ES DIR GEFÄLLT.

SPETSEN

AUFBAUANWEISUNG



BALTIMORE

(Bitte aufbewahren) (Stand 02.02.2024)

setone
by Musterring

Nutzen Sie die Sicherheit einer großen Marke.



5 Jahre Garantie.

Auf set one Möbel ist Verlass.

Die Garantiebestimmungen, Gebrauchs- und Pflegeanweisungen sind im set one Möbel-Gütepass geregelt.



Service-Information

Sie erreichen uns per E-Mail oder über das Servicetelefon zu den üblichen Geschäftszeiten.



Individualität

Die set one Produktkennzeichnung belegt, dass Sie ein Unikat gekauft haben.



Pflege

Wir empfehlen Musterring Pflegeprodukte.

Lederpflege & Reinigung

Stoff-/ Mikrofaserpflege & Reinigung

Holzpflege und Sonderprodukte



Zu bestellen unter www.musterring-care.com oder unter der kostenlosen Beratungsnummer + 49 (0) 800 / 88 88 885.

Bei Fragen sprechen Sie uns bitte an; wir helfen Ihnen gerne weiter.

Zur Werterhaltung Ihrer Möbel

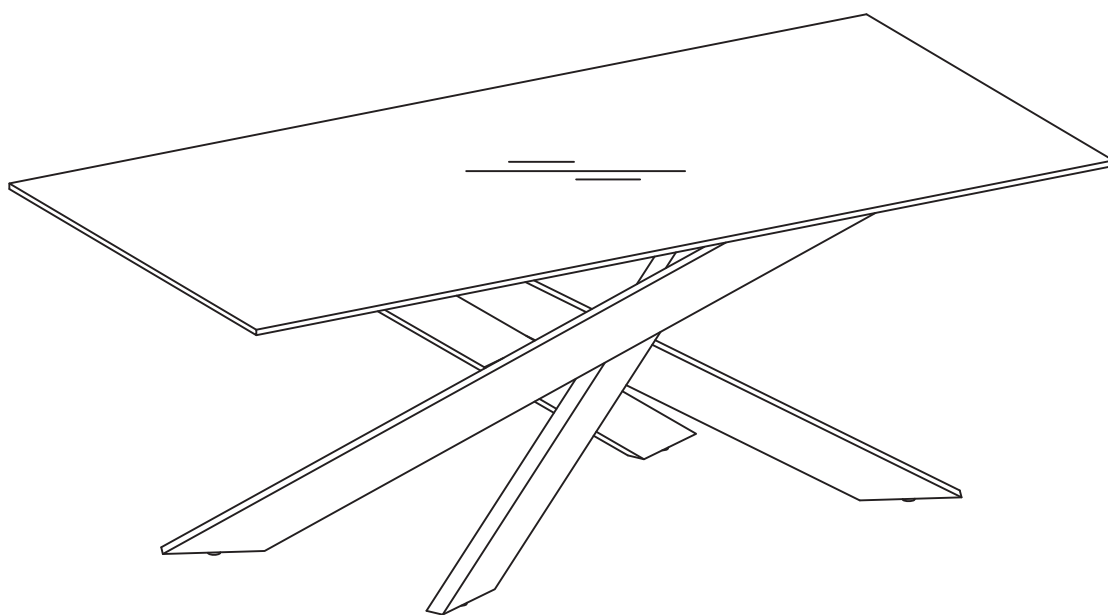

BALTIMORE

			✓
①	1	1000x2000x24	
②	2	1681x100x40	
③	2	1430x100x40	
④	1	356x168x30	

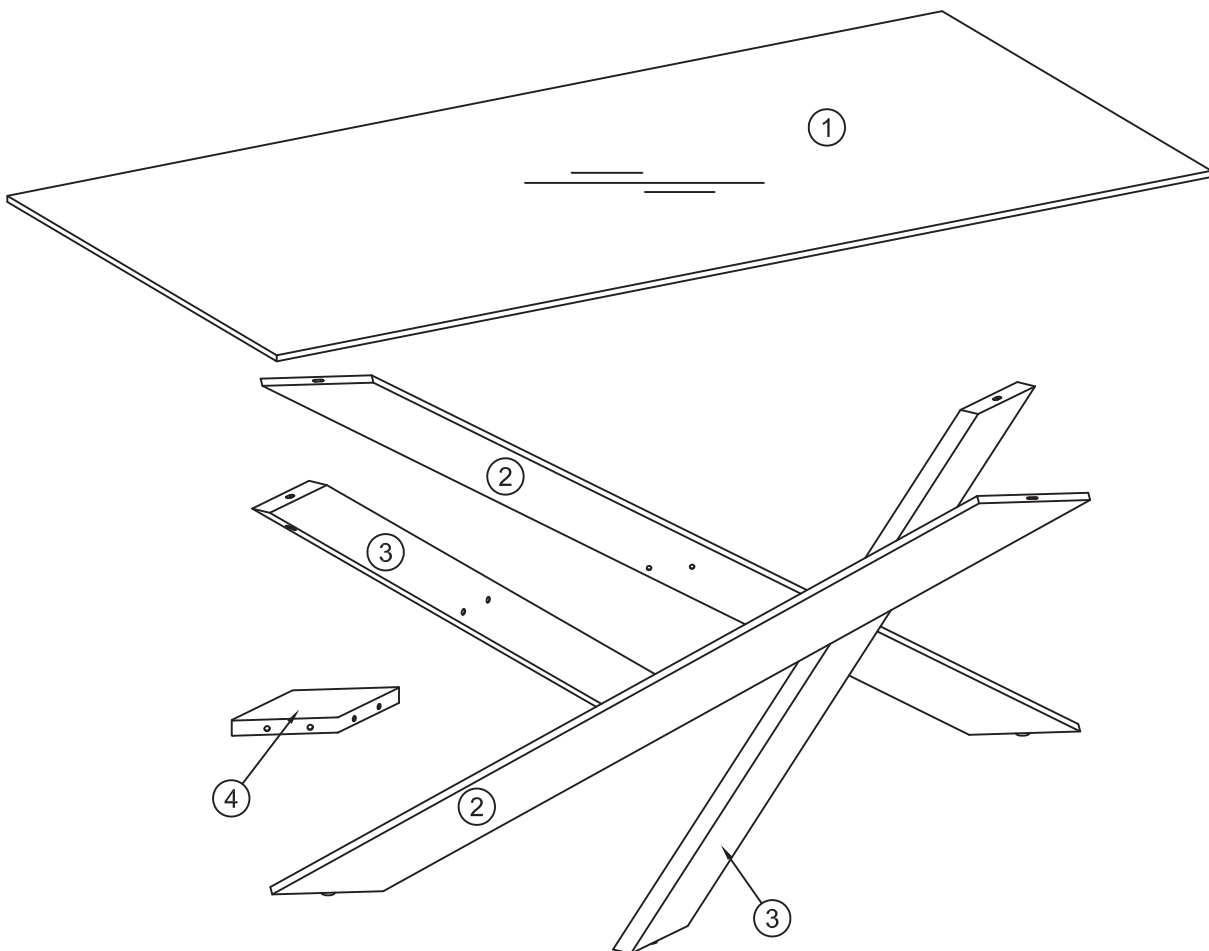

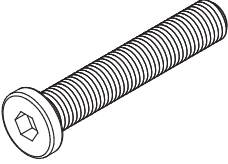
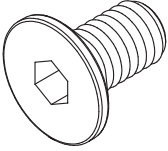
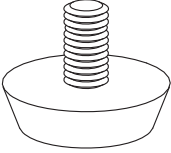
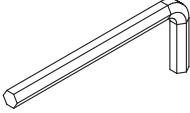
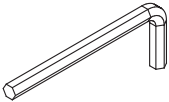
<p>A x 4</p>  <p>M8x45 mm</p>	<p>B x 8</p>  <p>M8x15 mm</p>	<p>C x 4</p>  <p>Ø30/M8</p>	<p>D x 1</p>  <p>5 mm</p>	<p>E x 1</p>  <p>4 mm</p>
--	--	--	--	--

1

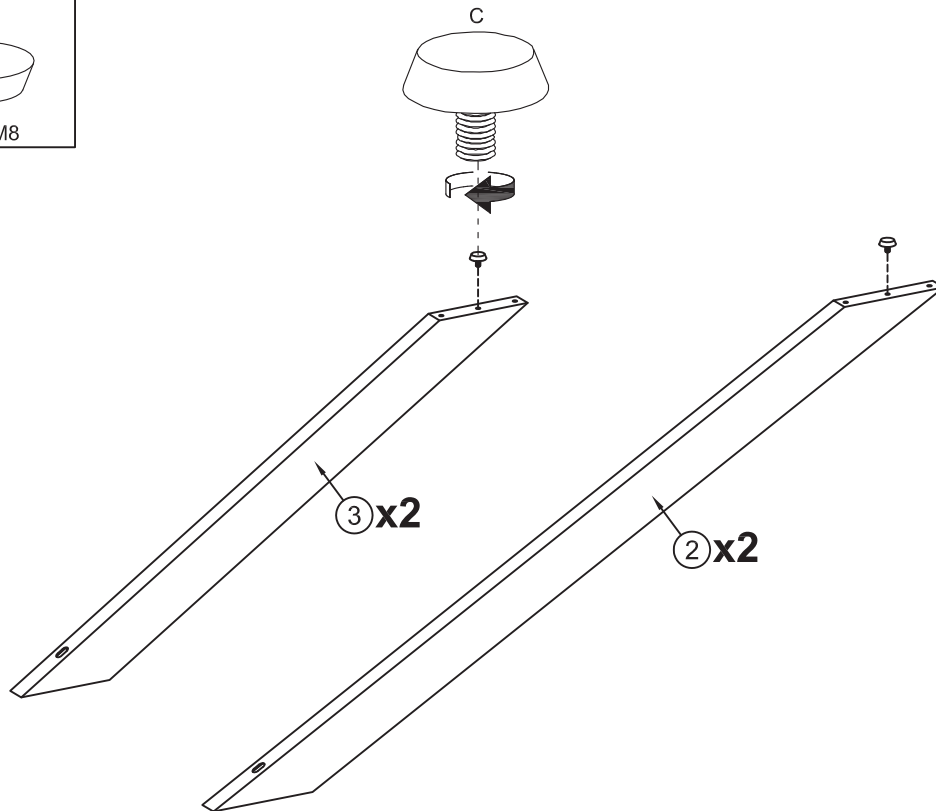
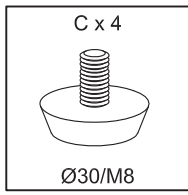

2

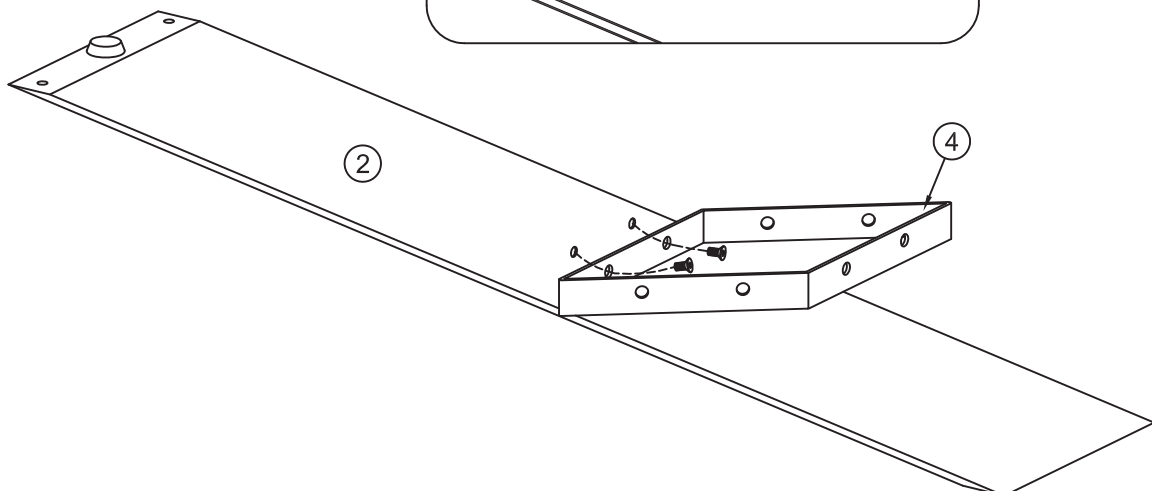
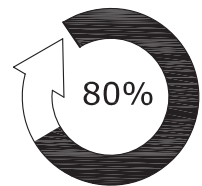
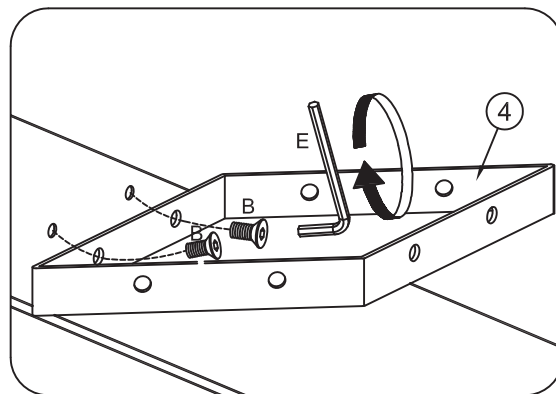
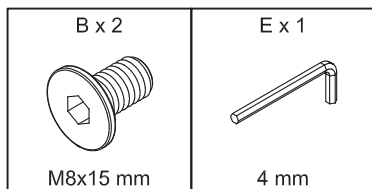

3

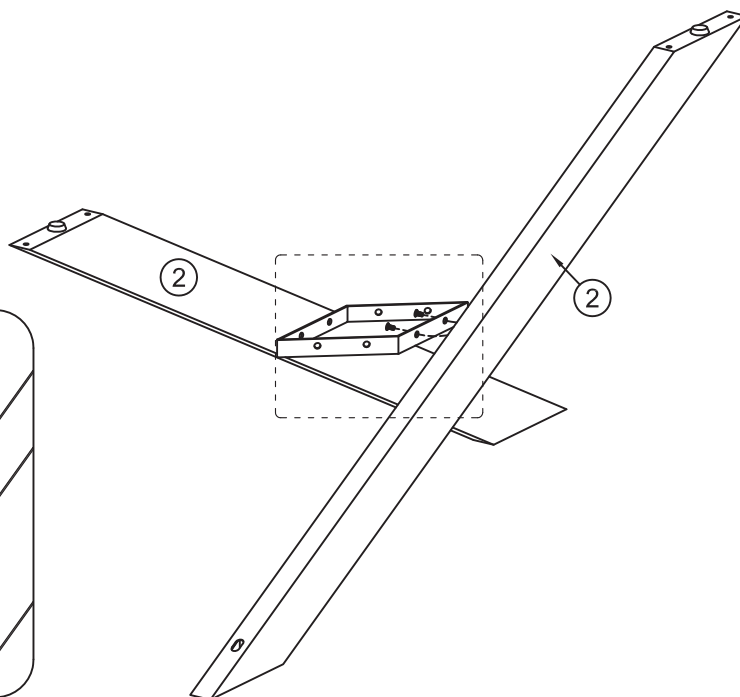
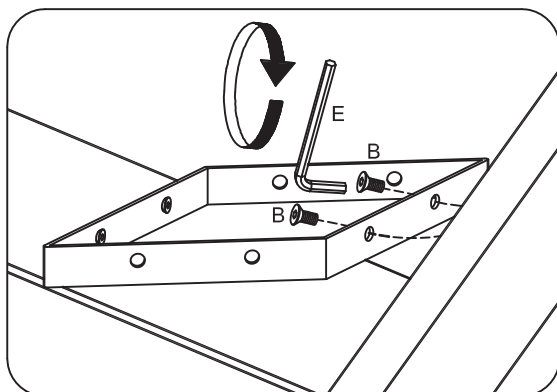
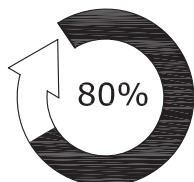
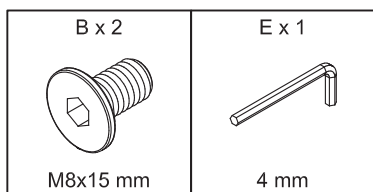

4

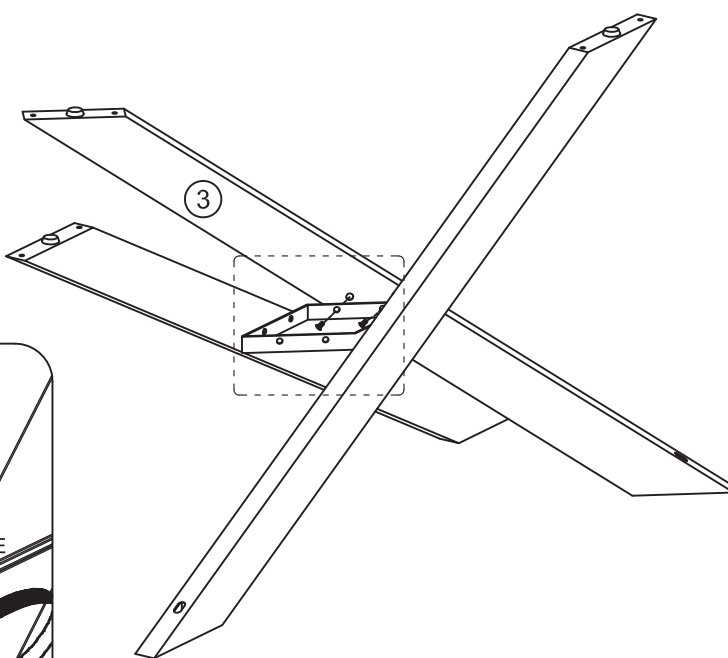
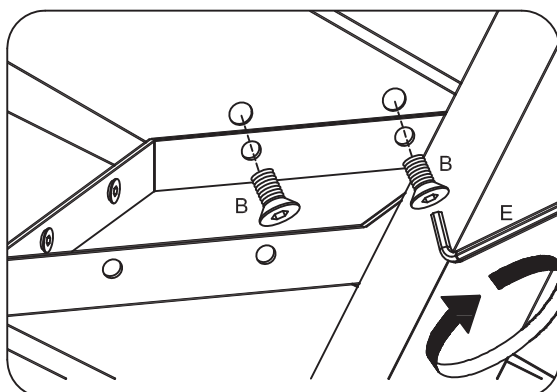
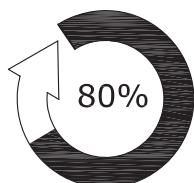
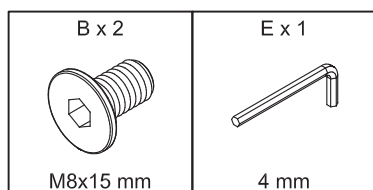

5

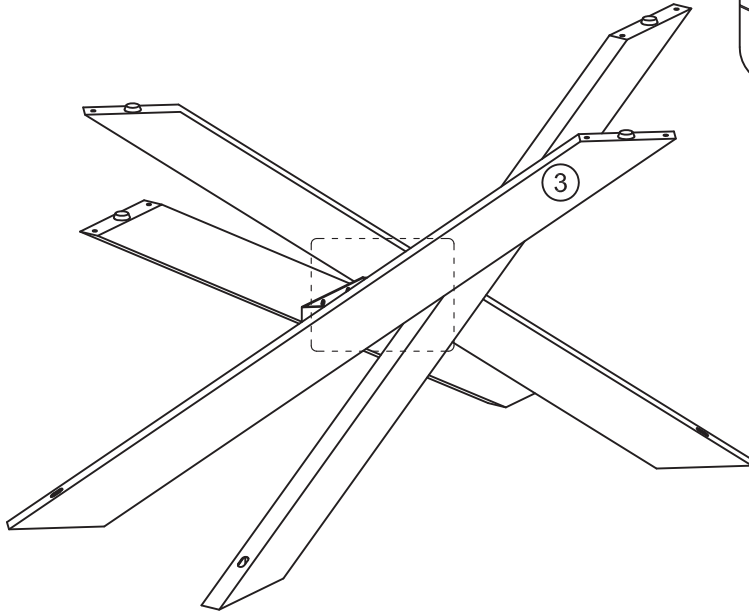
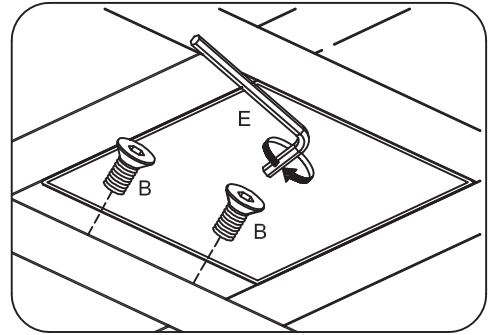
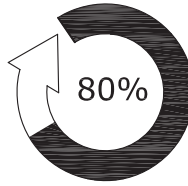
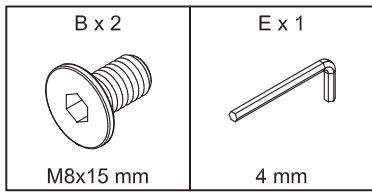

6

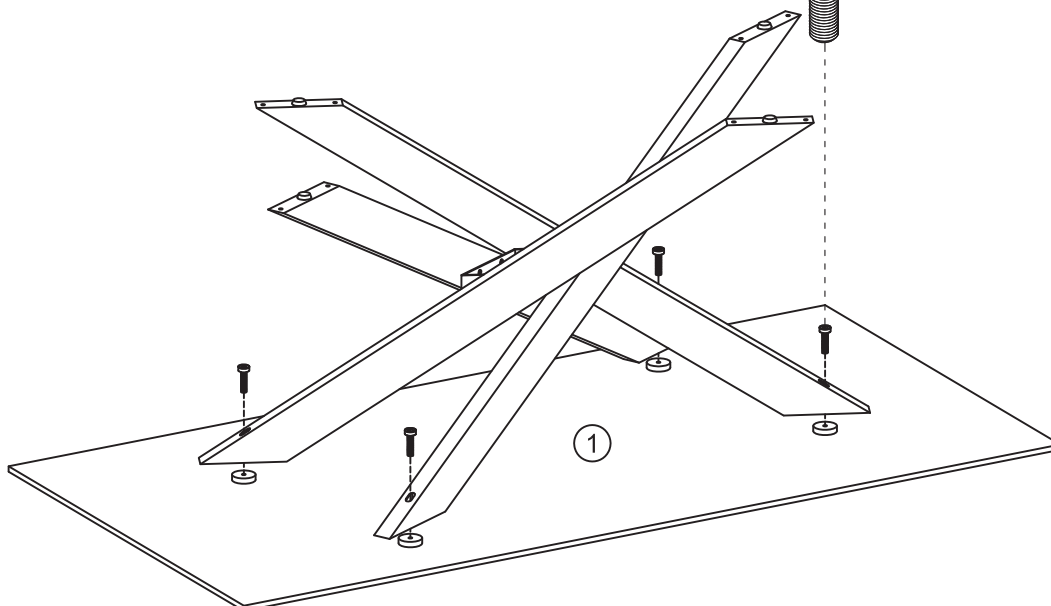
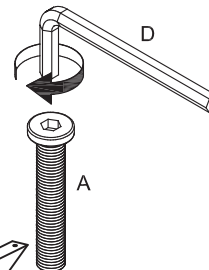
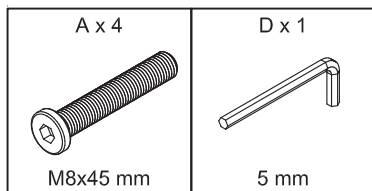

7

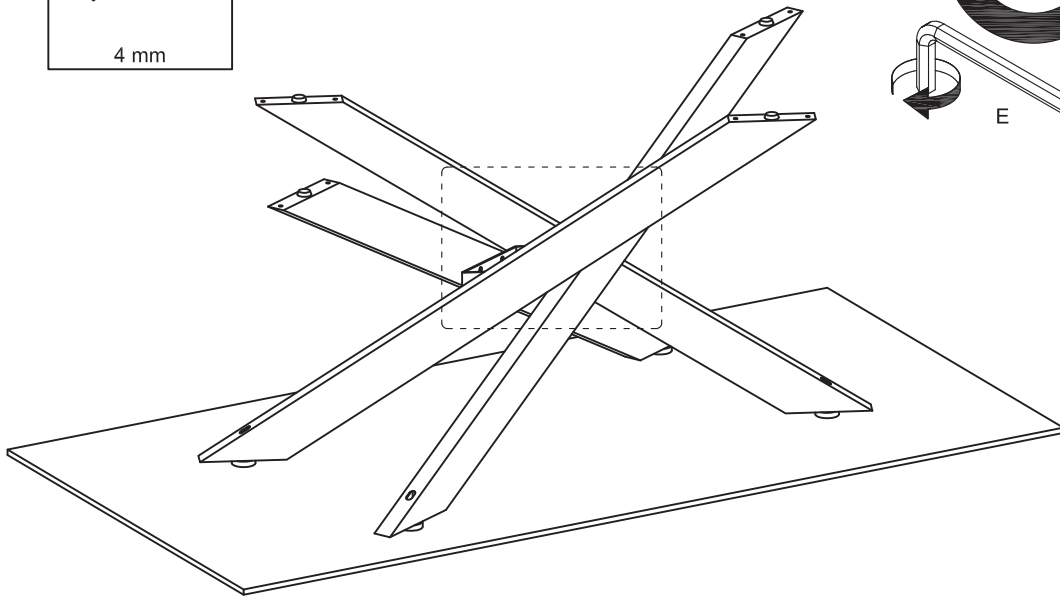
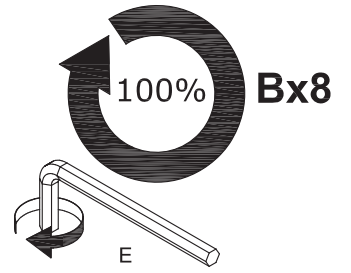
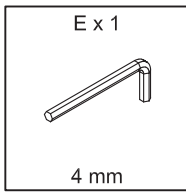

8

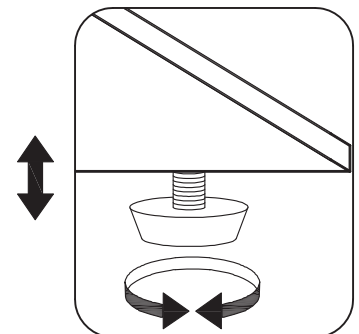
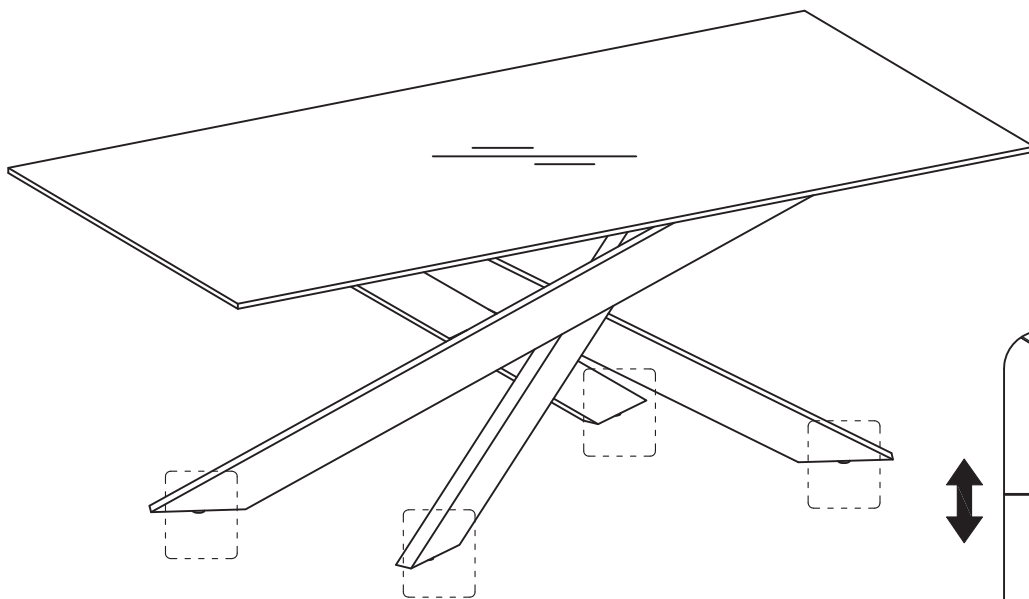

9

